

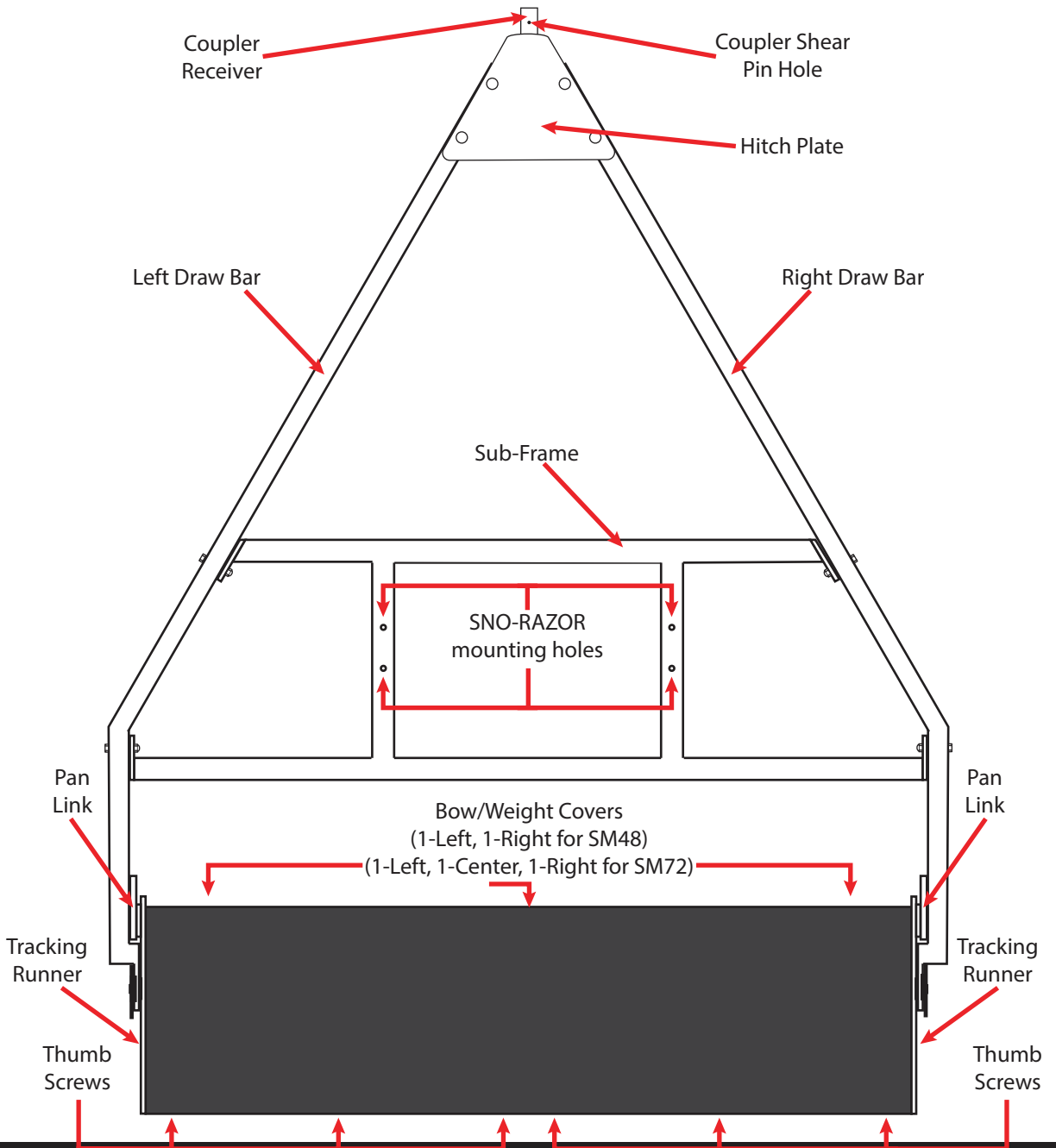

SNO-MASTER[®]
Assembly Instructions



TOOLS



7/16 (11MM) WRENCH

1/2 (13MM) WRENCH

9/16 (14MM) WRENCH



7/16 (11MM) SOCKET

1/2 (13MM) SOCKET

9/16 (14MM) SOCKET

& RACHET



**NEEDLE NOSE
PLIERS**



**PHILLIPS
SCREWDRIVER**

PARTS & HARDWARE

CHASSIS ASSEMBLY

- 1 - 48" OR 72" SNO-MASTER® CHASSIS
- 2 - CHASSIS TRACKING RUNNER
- 4 - 1/4-20 X 3/4" STAINLESS STEEL HEX BOLTS
- 2 - 1/4-20 X 3/4" STAINLESS STEEL CARRIAGE BOLTS
- 6 - 1/4-20 STAINLESS STEEL NYLOCK NUTS
- 2 - PAN ADJUSTMENT LINK
- 2 - PAN LINK SPACER
- 2 - 3/8" STAINLESS STEEL WASHERS
- 2 - 3/8-16 X 1-1/2" STAINLESS STEEL HEX BOLT
- 2 - 3/8-16 STAINLESS STEEL NYLOCK NUTS

DRAWBAR ASSEMBLY

- 1 - RIGHT DRAWBAR
- 1 - LEFT DRAWBAR
- 2 - 1/2" SAE WASHER
- 2 - .125 X 1-15/16" STAINLESS STEEL HITCH PINS

HITCH PLATE ASSEMBLY

- 1 - UPPER HITCH PLATE
- 1 - LOWER HITCH PLATE
- 4 - 5/16-18 X 3" STAINLESS STEEL CARRIAGE BOLTS
- 4 - 5/16-18 STAINLESS STEEL NYLOCK NUTS
- 1 - 6" PIN COUPLER W/ DETENT PIN OR 6" RING COUPLER
- 2 - 3/16" X 1-9/16" SHEAR PINS

SUB-FRAME ASSEMBLY (INCLUDED FOR 72" CHASSIS)

- 4 - 3/8-16 X 1-3/4" STAINLESS STEEL HEX BOLTS
- 4 - 3/8-16 STAINLESS STEEL NYLOCK NUTS

12" WING SET (OPTIONAL)

- 1 - LEFT 12" WING
- 1 - RIGHT 12" WING
- 4 - 1/4-20 X 7/8" STAINLESS STEEL HEX BOLTS
- 4 - 1/4-20 STAINLESS STEEL NYLOCK NUTS

ASSEMBLY STEP 1

Prepare your work space for assembly by clearing an area approximately 8' x 8'. Remove the SNO-MASTER® Chassis from the packing material and place (black urethane combs down) on two 4" x 4" x 12" wood blocks placed in the center of the work space.

STEP 1: PAN ADJUSTMENT LINK

Remove the rear thumb screws from the left and right Bow Covers.

Prepare the PAN ADJUSTMENTS LINKS by sliding a washer, followed by a Pan Link (bottom hole of the two hole end), and last is the spacer or 2 thick washers. Then slide the prepared link bolt into the chassis through hole "A" and tighten with the $\frac{5}{8}$ Nylock Nut.

Tighten until the link is able to be rotated by hand, but is tight enough to remain in place when lifted. Repeat on the opposite side of the chassis.

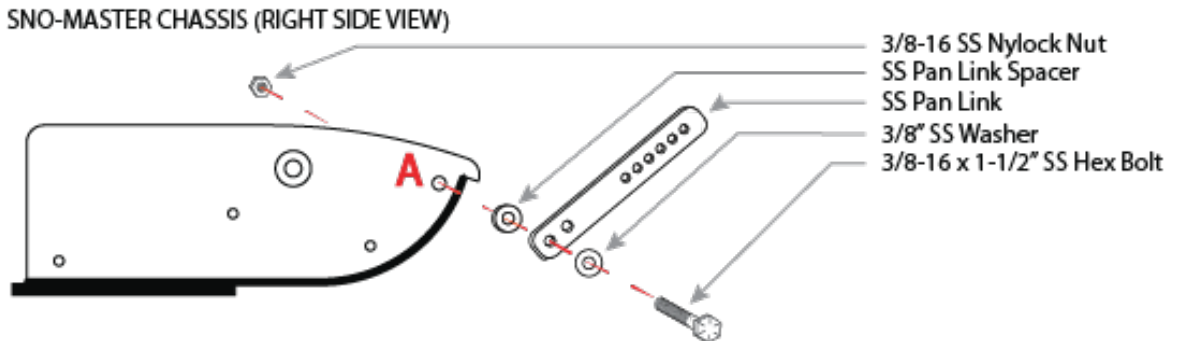

ASSEMBLY STEP 2

STEP 2: CHASSIS TRACKING RUNNERS

Remove both Stainless Steel Runners and hardware from the packaging.

The nose, or front, of the runner has a square hole. Insert the Carriage Bolt through the square hole and into hole "B" of the chassis. From inside the chassis, under the bow cover, finger tighten the 1/4-20 Nylock Nut to the Carriage Bolt.

-Without Wing Set-

Insert 1/4-20 x 3/4" Stainless Steel Hex Bolt from outside the chassis through the middle hole of the Runner and into hole "C" of the chassis.

From inside the chassis, under the bow cover, finger tighten the 1/4-20 Nylock Nut to the Hex Bolt. Insert 1/4-20 x 3/4" Stainless Steel Hex Bolt from outside the chassis through the last hole of the Runner and into hole "D" of the chassis.

From inside the chassis, under the bow cover, finger tighten the 1/4-20 Nylock Nut to the Hex Bolt. Once all bolts are inserted and nuts are on, tighten all three nuts using a 7/16 socket and wrench and repeat on the opposite side of the chassis.

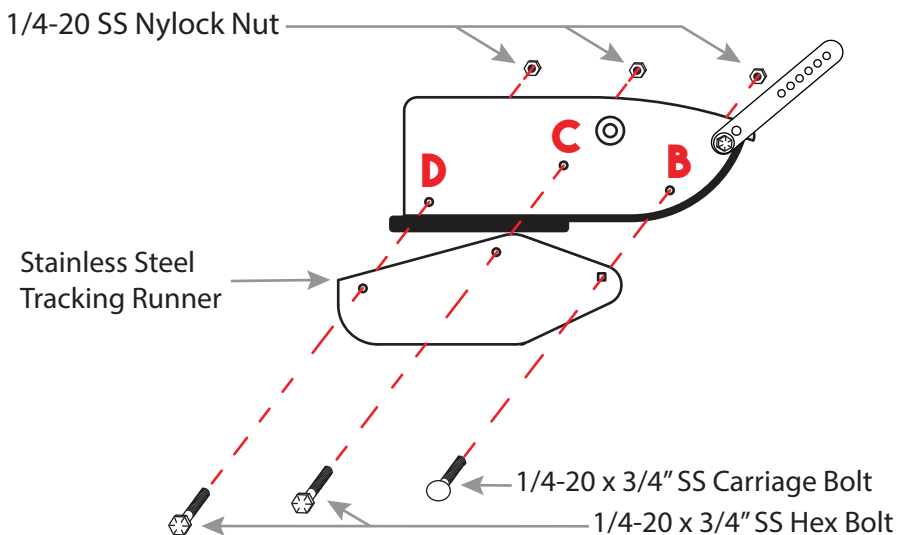

ASSEMBLY STEP 2

STEP 2: CHASSIS TRACKING RUNNERS

-With Wing Set-

Identify the right and left wings using the examples shown below. Insert $\frac{1}{4}$ -20 x $\frac{7}{8}$ " Stainless Steel Hex Bolt from outside the chassis through the front wing bracket hole, then through the middle hole of the Runner and into hole "C" of the chassis. From inside the chassis, under the bow cover, finger tighten the $\frac{1}{4}$ -20 Nylock Nut to the Hex Bolt.

Insert $\frac{1}{4}$ -20 x $\frac{7}{8}$ " Stainless Steel Hex Bolt from outside the chassis through the back hole of the wing bracket and then the last hole of the Runner and into hole "D" of the chassis. From inside the chassis, under the bow cover, finger tighten the $\frac{1}{4}$ -20 Nylock Nut to the Hex Bolt.

Once all bolts are inserted and nuts are on, tighten all three nuts using a $\frac{7}{16}$ socket and wrench and repeat on the opposite side of the chassis.

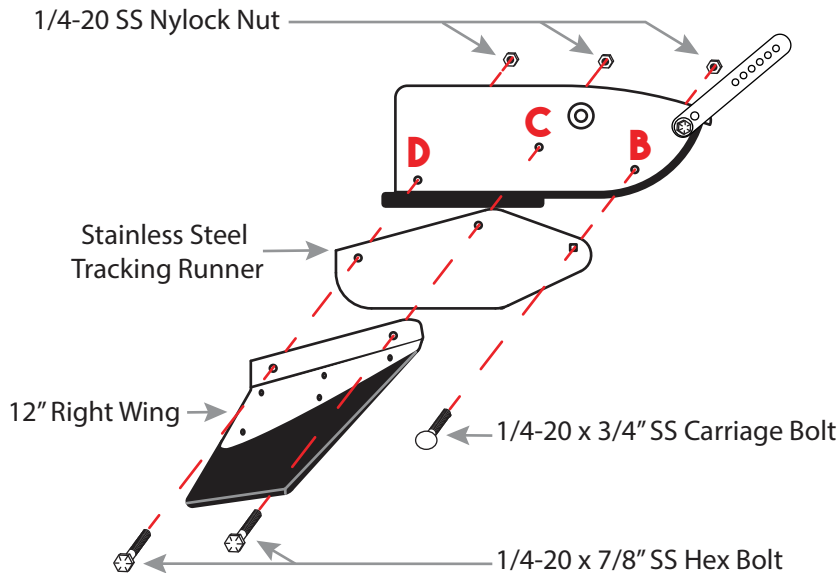

ASSEMBLY STEP 3

STEP 3: DRAWBARS

Remove the drawbars from the packaging and remove the yellow protective netting. Place the Drawbar Bracket over the Chassis Drawbar Pin with the SNO-MASTER label to the outside. Slide the washer over the Chassis Drawbar Pin and insert the Hitch Pin.

Repeat on the opposite side.

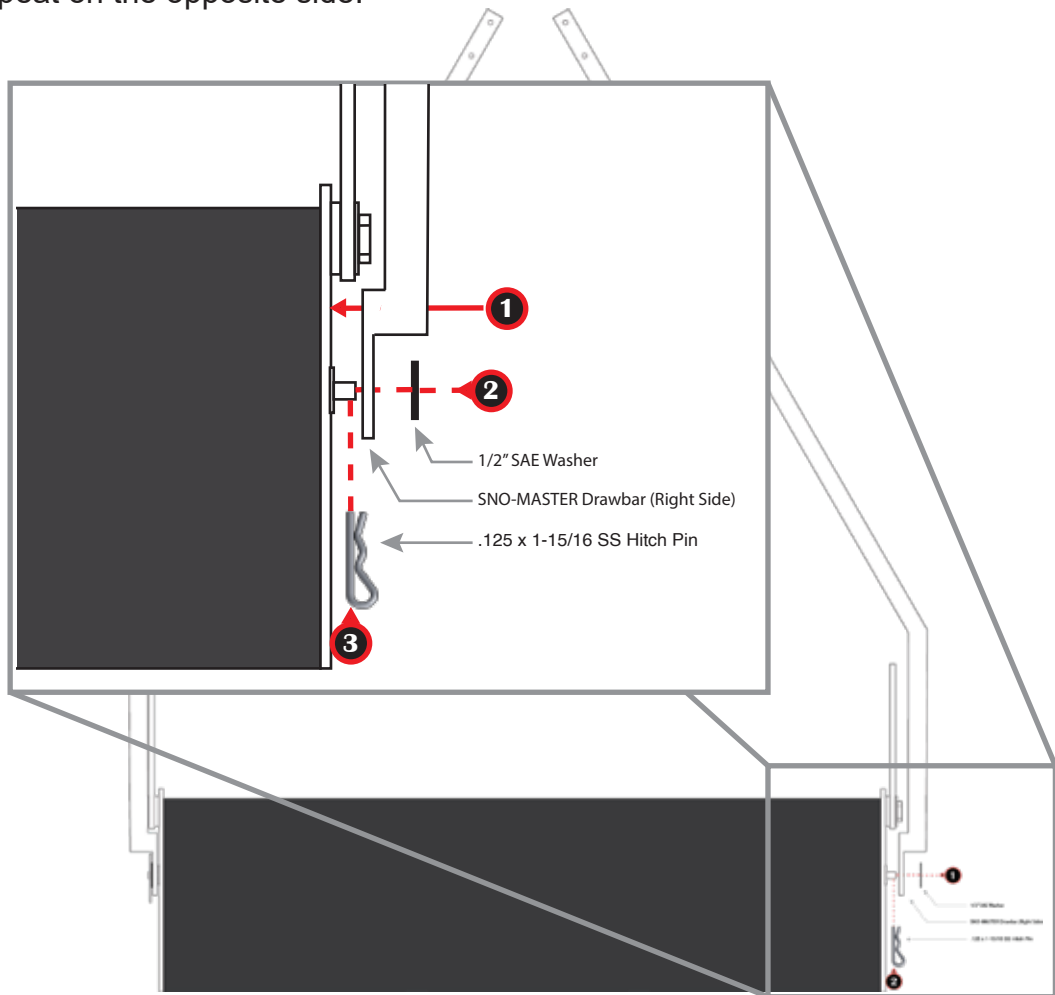

ASSEMBLY STEP 4

STEP 4: HITCH PLATE

Remove wrapping around the lower and upper hitch plate parts and hardware bag. Place the upper hitch plate (containing the square holes) on top of the drawbars.

Insert the Carriage Bolts through the plate and then down through the drawbars. Holding the drawbars up, place the lower hitch plate over the bolts extending down through the drawbars.

As you get a bolt through, finger tighten a Nylock Nut on until all four are finger tight. You may need to slightly rock the drawbars left and right to properly align the bolts and holes of the plates and drawbars.

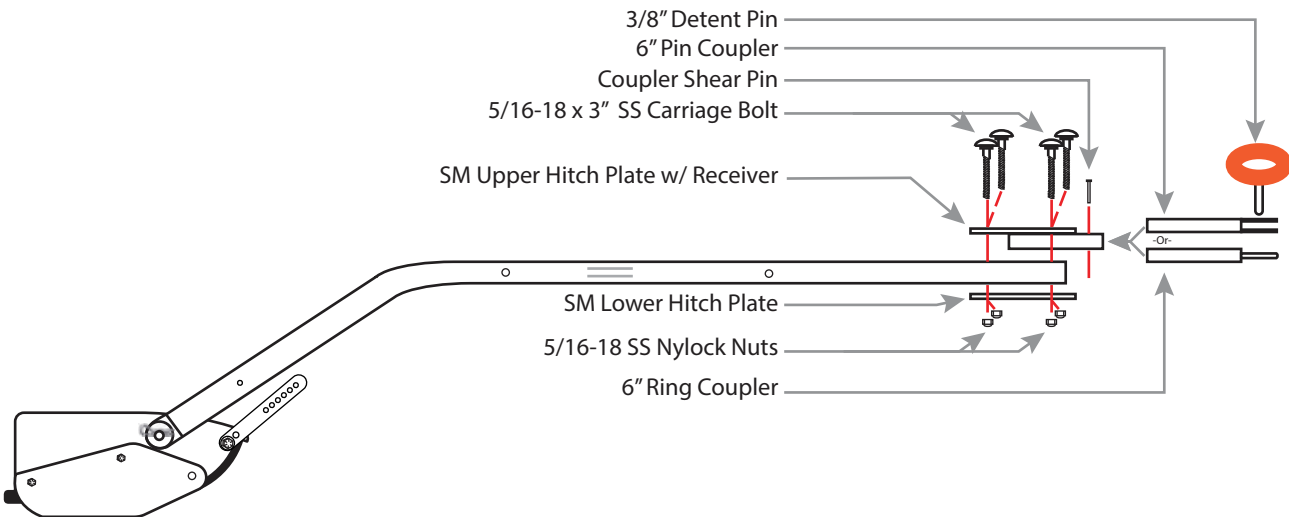

****DO NOT TIGHTEN HITCH PLATE BOLTS UNTIL SUB-FRAME IS INSTALLED****
(IF INCLUDED WITH PACKAGE OR ACCESSORIES PURCHASED)

ASSEMBLY STEP 5

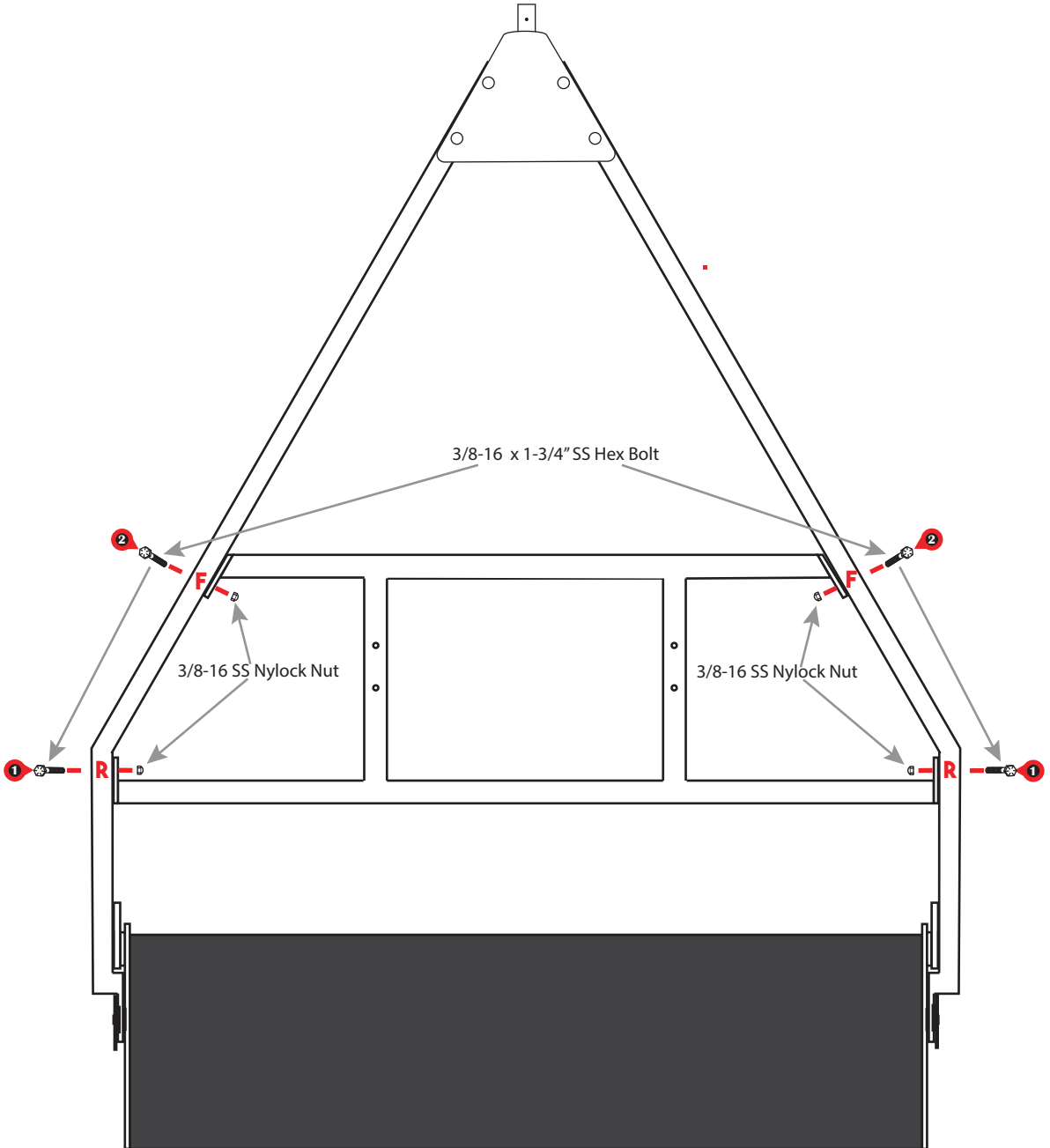

ASSEMBLY STEP 5

STEP 5: SUB-FRAME

Unwrap the Sub-frame and place between the drawbars with the long section closest to the chassis and the Deflector mounting holes facing down or under the Sub-frame.

Insert the Stainless Steel Hex Bolt from outside of the drawbars then through the Drawbar Hole "R" and then through the Rear Drawbar Bracket.

Finger tighten the Nylock Nut and proceed to the opposite side and repeat. With the rear of the Sub-frame secured with the bolts, swing the Sub-frame up to align the Drawbar Holes "F" with the Front Sub-frame Bracket. Insert the Stainless Steel Hex Bolts from the outside of the drawbars, through Drawbar Hole "F" and then through the Front Drawbar Bracket.

Finger tighten the Nylock Nut and proceed to the opposite side and repeat. Once all four Sub-frame Bolts are in place, tighten using a 9/16 socket and wrench.

****TIGHTEN HITCH PLATE BOLTS****

ASSEMBLY STEP 6

STEP 6: COUPLER

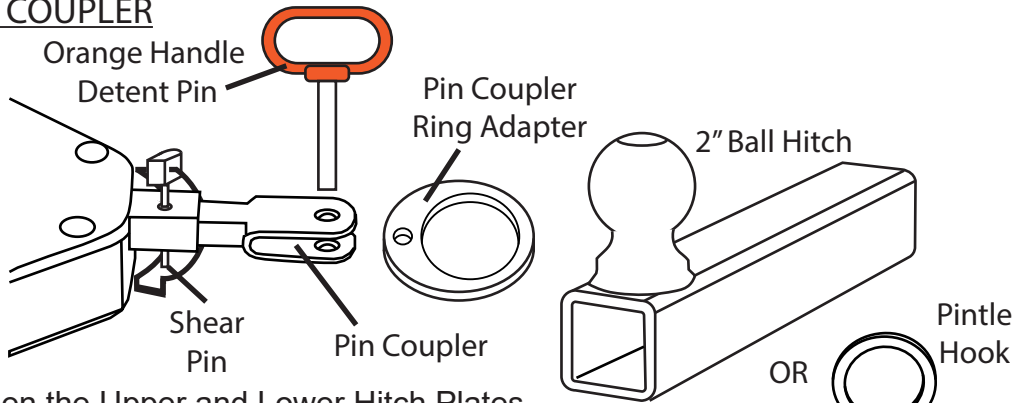

In between the Upper and Lower Hitch Plates is the Coupler Receiver, a 1- $\frac{1}{4}$ " square tube.

Locate the Pin Coupler in the hardware box and slide the coupler square tube into the coupler receiver tube until the Shear Pin holes are aligned. Once aligned, insert a Coupler Shear Pin and pull the locking loop over the receiver.

If installing on a 2" Ball or Pintle Hook, place the Pin Coupler Ring Adapter over the 2" Ball or on the hook. Slide the small hole on the Ring Adapter between the upper and lower tabs of the Pin Coupler. Insert the Orange Handle Detent Pin to lock in place.

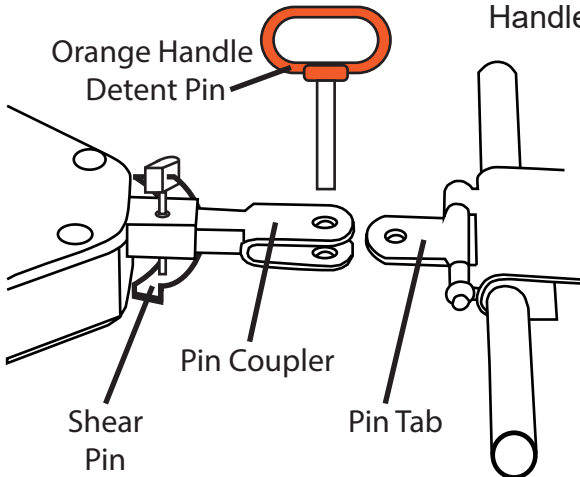

If installing on vertical swivel pin tab, slide the tab between the upper and lower tabs of the Pin Coupler and insert the Orange Handle Detent Pin to lock in place.

ASSEMBLY STEP 7

STEP 7: PAN LINK TO DRAWBAR

Remove the blocks below the chassis to allow the chassis to sit flat on the ground/floor of your work space.

Raise the drawbars slightly and at the same time rotate the Pan Adjustment Link until the Drawbars are nearly level and a hole in the Link aligns with the Drawbar Hole "L".

Once aligned, insert the Clevis Pin through Drawbar Hole "L" and then through the Pan Adjustment Link. Insert the Hitch Pin and repeat on the opposite side.

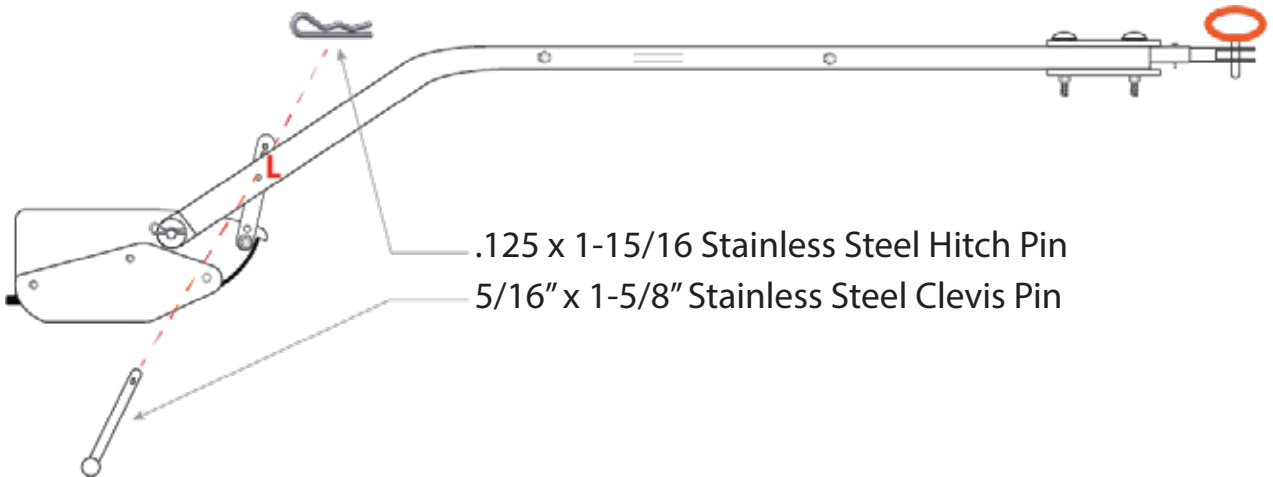

ASSEMBLY STEP 8

STEP 8: GROOMING SETUP

The SNO-MASTER® is assembled and ready to be attached to the towing machine, such as a Snowmobile or UTV with Tracks. Once the groomer has been attached, you are ready to adjust the angle of the Chassis Pan and add weight for the current snow conditions.

Remove the pan link clevis pins from both sides that attach the pan link to the drawbars. Attach the groomer to the towing machine using the pin or ring coupler provided with your package.

Add the appropriate weight to the towing machine that is typical during grooming to properly compress the suspension. Once compressed, the coupler will typically be approximately 15 to 19 inches above the ground for the drawbars to run parallel to the ground. If that height is greater than 19 inches, you can lower the nose of the chassis or purchase either a 3 inch or 5 inch offset coupler as needed.

Place the Angle Indicator with magnetic base to the chassis side runner. Raise or lower the nose of the chassis with the pan link clevis pin remove until the angle indicator is between 1 and 2 degrees. Replace the pan link clevis pin through the drawbar and pan link and secure with the hitch pin. Take note of which hole you use on the pan link and repeat on the other side.

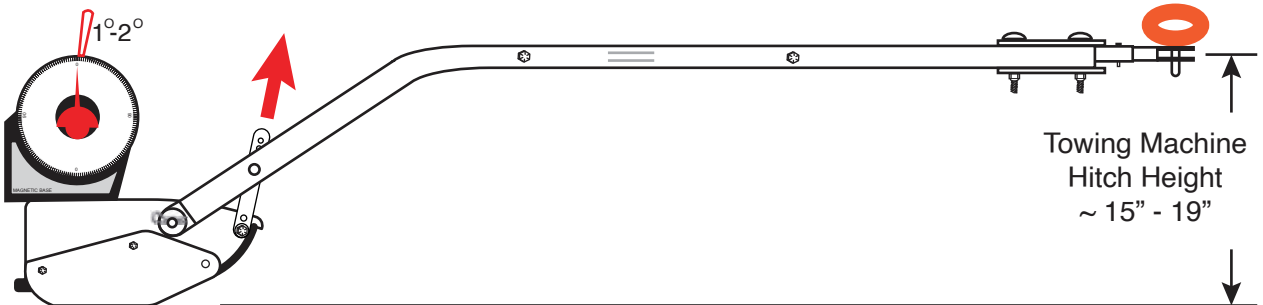

ASSEMBLY STEP 9

STEP 9: ADJUSTING WEIGHT

Adjusting the weight of your groomer is very important. Over-weighted groomers plow snow off the trail and can become more easily stuck. Under-weighted groomers will not fully compact the snow and leave ski/track marks from the towing machine. Correctly weighted SNO-MASTERS can handle everything from fresh mountain powder to wet slush, use less or no weight in powder conditions and more weight in hard/wet snow.

Increasing the weight of your SNO-MASTER 48, is accomplished placing standard 2" concrete blocks in the weight compartment, under the two black plastic weight covers. These blocks, also known as "Pavers" are 2" x 8" x 16" nominal size, weigh 16.5 lbs. Each and are available at most building supply centers. You should also obtain a couple of wooden spacer blocks, two pieces of 2"x 8"x 15" long to keep the concrete blocks in their intended place in the weight compartment.

A SM48 equipped with a SNO-RAZOR will likely use from one to three blocks. In mountain powder use no weight and slip the RAZOR and legs out of the bottom of the crosstube if necessary. A SM48 without a SNO-RAZOR will likely use from two to six blocks (99 lbs. maximum load))

HINTS:

- Weight adjustments can normally be made by opening only one weight cover and sliding the block or spacer over to the covered side.
- The blocks fit into the weight compartment snugly, remove any snow or ice from blocks before placing in the weight compartment (or defrost them by bringing them inside).
- Use one or two wooden spacer blocks as needed to keep the concrete blocks from sliding in the weight compartment and the groomer equally weighted.
- For easy line-up of the weight cover screws; start with the center screw, followed by the two outside screws, then lightly tighten the three screws. A little anti-seize on the tapped holes in the chassis will make the screws easy to remove for many years.
- A bouncing groomer is usually over-weighted, but may have too much chassis/pan angle.
- Crowning a trail: space a single 4" block (36 lbs.) on either the right or left side of the weight compartment and adjust your SNO-RAZOR ¼" deeper on that side, this will move snow to the center of the trail, then reverse direction and switch to the other side of the trail.

SNO-MASTER®



FROM OUR TEAM TO YOURS, THANK YOU TRUSTING YOUR SNOW GROOMING NEEDS TO US. MANY HOURS HAVE GONE INTO MAKING AND DELIVERING HIGH QUALITY EQUIPMENT THAT IS EXPECTED TO LAST A LIFETIME. WE HOPE YOU ENJOY UTILIZING YOUR SNOW GROOMERS EQUIPMENT AS MUCH AS WE ENJOYED MAKING IT.

1180 N Mountain Springs Pkwy
Springville, UT 84663
800-430-7120

www.snowgroomers.net

